

packed arrangement. The relation between the true orthorhombic unit cell and the cubic pseudocell is apparent in Table II. Calculated and observed *d* spacings are closely grouped corresponding to possible spacings of the face-centered-cubic pseudocell.

Acknowledgment.—Thanks are due Mr. C. E. Holley of this Laboratory for suggesting and encouraging this work.

LOS ALAMOS, NEW MEXICO

[CONTRIBUTION FROM THE IBM WATSON LABORATORY AT COLUMBIA UNIVERSITY]

Chemistry of the Group VB Pentoxides. VI. The Polymorphism of Nb₂O₅

BY FREDERIC HOLTZBERG, ARNOLD REISMAN, MARGARET BERRY AND MELVIN BERKENBLIT

RECEIVED SEPTEMBER 21, 1956

The polymorphism of Nb₂O₅ has been reinvestigated. Experimental results indicate the definite existence of two modifications and the possible existence of a third. The δ -modification recently reported has been shown to be a poorly crystallized state of the γ -phase. It is proposed that the α - and β -phases are identical, with the β -modification existing as a two-dimensional array. Transformation temperatures were found to be: amorphous to γ 435°, γ to α 830°. The densities are: amorphous 4.36 g./cm.³ at 25°, γ , 5.17 g./cm.³ at 25° and α , 4.55 g./cm.³ at 25°. None of the transformations was reversible. The α -phase was reindexed on the basis of a monoclinic unit cell with $a = 21.34$ Å., $b = 2.816$ Å., $c = 19.47$ Å. and $\angle \beta = 120^\circ 20'$ having 14 molecules/unit cell and an X-ray density of 4.52 g./cm.³. The freezing point of Nb₂O₅ obtained in the study was 1491°.

Previous investigations pertaining to the chemistry of the Group VB pentoxides and their reactions with alkali oxides and carbonates have included studies of the polymorphism of Ta₂O₅¹ and V₂O₅.² Examination of the temperature-phase relationships of Nb₂O₅, in addition to completing the study of the comparative polymorphism of the pentoxides, may help explain the non-model behavior exhibited by the systems K₂O-Ta₂O₅¹ and K₂O-Nb₂O₅.³

In 1941, Brauer⁴ reported that Nb₂O₅ existed in three crystalline modifications having the following transformations: amorphous to γ 500°, γ to β 1000° and β to α 1100°. In 1951, Hahn⁵ published X-ray data for an unspecified form of Nb₂O₅. The pattern did not correspond to Brauer's α -, β - or γ -forms. Subsequently Schäfer, *et al.*,^{7,8} presented the results of a partial X-ray investigation of the system Nb₂O₅-Ta₂O₅ in which a study of the polymorphism of Nb₂O₅ was included. This work confirmed the α -, β - and γ -polymorphs reported by Brauer: however, the transformation temperatures were significantly different. Furthermore, contrary to evidence given by Brauer, the γ to β transformation was found to be reversible. The reversibility of the α to β transformation was not clarified. Schäfer also observed that the crystallization of the amorphous oxide sometimes results in a mixture of β - and γ -Nb₂O₅. Lapitskiĭ, *et al.*,⁹ showed with thermal analysis that the amorphous pentoxide exhibited an exotherm at 609°. The temperature of this heat effect is not coincidental with any of the reported transition temperatures.

Recently, Frevel and Rinn¹⁰ reported a δ -form which was indexed on the basis of a pseudohexagonal unit cell. The δ -form is apparently converted to the γ -phase at 700°, a contradiction of Brauer's results. The method of preparation of the δ -form was not specified.

In order to resolve the uncertainties concerning the number of polymorphs of Nb₂O₅, and the temperatures and reversibilities of transformations between phases, it was felt that a complete re-evaluation of previously reported data was in order.

Experimental Procedure

Preparation of Reagents.—Sublimed NbCl₅ prepared from high purity niobium¹¹ was used for the preparation of Nb₂O₅. The pentachloride was hydrolyzed in distilled water and the precipitated Nb₂O₅ was washed until the filtrate was free of chloride ion. The washings, with intermediate digestions at boiling temperatures, were continued through five further cycles. After drying for 24 hours at 100° the pentoxide was found to be amorphous to X-rays. The excessive washing and digestion treatment was employed because, as will be shown, the transformation temperatures of the different pentoxide phases were impurity sensitive.

"High Purity"¹² Nb₂O₅ was used in experiments designed to determine the reversibility of phase transformations. Prior to use the oxide was heated at 1200° for 24 hours to ensure complete conversion to the high temperature form. A portion of the Nb₂O₅ was fused with K₂CO₃, dissolved in water and amorphous hydrated Nb₂O₅ was precipitated as described in an earlier paper.¹³ X-Ray analysis indicated that this material was also amorphous.

Differential Thermal Analysis.—A large number of furnaces specifically designed for heating curve analysis have been described in the literature. The general construction involves the use of a mobile furnace which rolls into position over a fixed sample holder and thermocouple assembly. The holder and thermocouple assembly are often difficult to clean and frequently require refabrication for each analysis. In addition the apparatus is costly, requiring elaborate engineering. The problems inherent in the standard

(1) A. Reisman, F. Holtzberg, M. Berkenblit and M. Berry, *THIS JOURNAL*, **78**, 4514 (1956).

(2) F. Holtzberg, A. Reisman, M. Berry and M. Berkenblit, *ibid.*, **78**, 1536 (1956).

(3) A. Reisman and F. Holtzberg, *ibid.*, **77**, 2115 (1955).

(4) G. Brauer, *Z. anorg. allgem. Chem.*, **248**, 1 (1941).

(5) Consistent with accepted nomenclature, the highest temperature phase will be denoted as α which corresponds to Brauer's "Hochform."

(6) R. B. Hahn, *THIS JOURNAL*, **73**, 5091 (1951).

(7) H. Schäfer and G. Breil, *Z. anorg. allgem. Chem.*, **267**, 265 (1952).

(8) H. Schäfer, A. Durkop and M. Jori, *ibid.*, **275**, 19 (1954).

(9) A. V. Lapitskiĭ, Y. P. Simanov and E. I. Yarembash, *J. Phys. Chem. Moskau*, **26**, 56 (1952).

(10) L. K. Frevel and H. N. Rinn, *Anal. Chem.*, **27**, 1329 (1955).

(11) The NbCl₅ was obtained from the A. D. Mackay Co. The niobium from which the pentachloride was prepared was Fansteel High Purity Grade containing a maximum impurity of 0.2% Ta.

(12) The high purity of Nb₂O₅ was obtained from the Fansteel Metallurgical Co. and contained as a maximum impurity 0.2% Ta.

(13) (a) A. Reisman, F. Holtzberg, S. Triebwasser and M. Berkenblit, *THIS JOURNAL*, **78**, 719 (1956); (b) See Errata for ref. 11 in *THIS JOURNAL*, **78**, 6423 (1956).

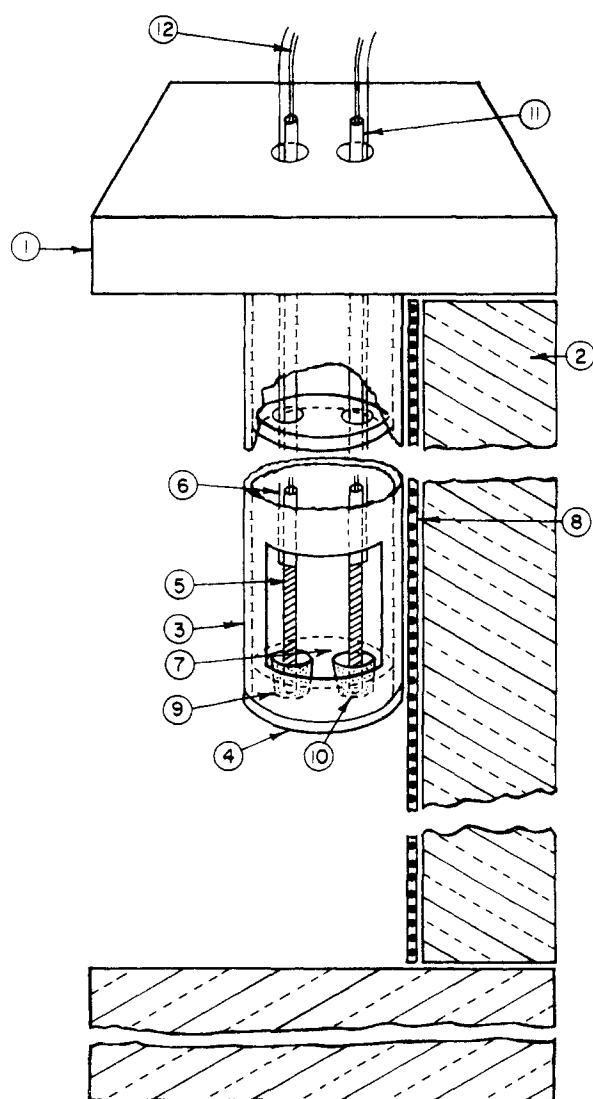

Fig. 1.—D.T.A. furnace and sample assembly: 1, firebrick, air-dry cement coated; 2, firebrick; 3, alumina; 4, alumina; 5, platinum protecting capsule; 6, platinum 20 mil ground wire; 7, firebrick crucible seat; 8, alumina $\frac{1}{8}$ " pitch furnace tube; 9, 1-cc. platinum crucible with 90-mesh Alundum powder; 10, 1-cc. platinum crucible with sample; 11, $\frac{1}{8}$ " 2-hole thermocouple tubing; 12, Pt-10 Rh B & S #28 wire.

design have been eliminated with the construction of a new D.T.A. apparatus, Fig. 1. A stationary furnace consisting of a 12 in. Kanthal wound $1\frac{1}{2}$ in. i.d. core set into 4 in. \times 8 in. firebrick is mounted vertically. The sample holder and thermocouple assembly are mounted in a $1\frac{3}{16}$ in. o.d. ceramic hollow cylinder which slides into the furnace and seats at the appropriate height. The thermocouples are supported in $\frac{1}{8}$ in. two-hole alumina insulating rods that are guided through centering holes located in two parallel ceramic discs. Such an arrangement permits removal of the thermocouples after a heating curve. 0.2–0.5 g. charges contained in 1-cc. platinum crucibles are easily loaded into the holder through a port cut in the alumina cylinder. The time required for manipulation of the equipment prior to a run is approximately 1 minute. The electronic components of the D.T.A. apparatus have been previously described.^{1–3} Heating rates were of the order 0.5–2°/minute with 5–34 \times amplification of the differential signal.

The freezing point of Nb_2O_5 was determined using cooling curves as previously described.^{1–3}

Sensitivity of D.T.A. Equipment.—In order to evaluate the smallest spontaneous heat change that could be detected with D.T.A. apparatus, potassium metaniobate was used as a calibrant. KNbO_3 has two solid state transformations, one at 215° and the other at 425°. The latent heat associated with the orthorhombic to tetragonal transformation at the lower temperature is 69 ± 5 cal./mole and that of the tetragonal to cubic transformation is 134 ± 5 cal./mole.¹⁴ Consequently a 0.5-g. sample would absorb 0.2 cal. at 215° and 0.4 cal. at 425°. The signal-to-noise ratio for the lower endotherm was approximately 3 and thus it is estimated that a spontaneous heat change of 0.1 cal. can be readily detected.

Heat Treatments and X-Ray Analysis.—Samples contained in platinum crucibles were placed in furnaces whose temperatures were controlled to within $\pm 5^\circ$ throughout the heating period. Temperatures were measured with Pt-10 Rh thermocouples. All X-ray traces were obtained with a General Electric XRD-5 diffractometer using nickel filtered copper radiation.

Single crystals of $\alpha\text{-Nb}_2\text{O}_5$ were obtained by cooling the molten oxide. The resulting crystals were twinned, strained and exhibited poor external morphology; however, sufficient X-ray data were collected with a precession camera to establish the crystal class and unit cell size. It was not possible to obtain single crystals of lower temperature phases because, as will be shown, the transformations are not reversible.

Discussion of Experimental Results

A. The Amorphous to Crystalline Transformation.—Figure 2 is a D.T.A. heating curve starting with the amorphous Nb_2O_5 prepared by the hy-

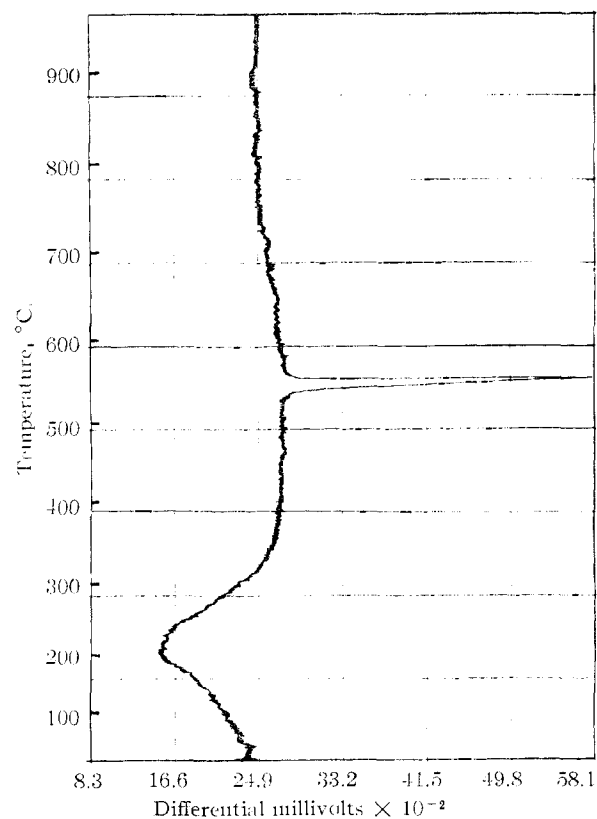

Fig. 2.—D.T.A. heating curve of amorphous Nb_2O_5 .

drolysis of NbCl_5 as previously described. The first broad endotherm corresponds to the evolution of surface water. The endotherm extends from room temperature to 400°. Although very slow heating rates were used, static experiments were

(14) S. Triebwasser and J. Halpern, *Phys. Rev.*, **98**, 1562 (1955)

necessary in order to more nearly approximate equilibrium conditions. Constant temperature weight loss experiments showed that surface absorbed water is completely removed at 400°; Table I, part A.

TABLE I
HEAT TREATMENT EXPERIMENTS

| PART A | | | |
|-------------------------------------|------------|-----------|-----------------------|
| A ^a dried at 100° 24 hr. | Temp., °C. | Time, hr. | Cumulative % wt. loss |
| | 120 | 16 | 1.77 |
| | 150 | 16 | 4.04 |
| | 300 | 16 | 9.52 |
| | 400 | 16 | 9.86 |
| | 450 | 24 | 9.86 |
| | 500 | 22 | 9.86 |
| | 520 | 22 | 9.86 |

| PART B | | | |
|-------------|------------|-----------|-------------|
| Orig. phase | Temp., °C. | Time, hr. | Final phase |
| A | 440 | 23 | A |
| A | 440 | 64 | γ |
| A | 430 | 96 | A |
| A | 430 | 215 | A |

| PART C | | | |
|-------------|------------|-----------|---------------------|
| Orig. phase | Temp., °C. | Time, hr. | Final phase |
| A | 702 | 23 | γ |
| A | 645 | 23 | γ |
| A | 602 | 23 | ^b γ' + γ |
| A | 550 | 24 | γ' |
| A | 550 | 72 | γ' + γ |
| A | 540 | 138 | γ' + γ |
| A | 520 | 72 | γ' |
| A | 520 | 140 | γ' |
| A | 520 | 232 | γ' |
| A | 520 | 328 | γ' + γ |
| A | 510 | 528 | γ' + γ |
| A | 488 | 96 | γ' |
| A | 488 | 165 | γ' |
| A | 488 | 550 | γ' + γ |
| A | 463 | 23 | γ' |

| PART D | | | |
|-------------|------------|-----------|-------------|
| Orig. phase | Temp., °C. | Time, hr. | Final phase |
| A | 956 | 23 | α + α' |
| A | 905 | 23 | α + α' |
| A | 857 | 67 | α + α' |
| A | 833 | 168 | α + α' |
| A | 818 | 116 | γ |
| A | 804 | 120 | γ |
| A | 795 | 144 | γ |
| α + α' | 1145 | 12 | α |
| α + α' | 1095 | 23 | α |
| α + α' | 1050 | 23 | α + α' |
| α + α' | 1000 | 432 | α + α' |
| α + α' | 997 | 23 | α + α' |

| PART E | | | |
|-------------|------------|-----------|-------------|
| Orig. phase | Temp., °C. | Time, hr. | Final phase |
| α | 1150 | 336 | α |
| α | 995 | 384 | α |
| α | 905 | 384 | α |
| α | 850 | 384 | α |
| α | 798 | 336 | α |
| α | 754 | 336 | α |

| | | | |
|---------------------|------|-----|------------|
| α | 706 | 336 | α |
| α | 644 | 168 | α |
| α | 600 | 360 | α |
| α | 500 | 336 | α |
| α | 477 | 216 | α |
| α | 430 | 120 | α |
| α | -80 | 124 | α |
| α | -196 | 120 | α |
| α + α' ^s | 1150 | 408 | α |
| α + α' | 1050 | 144 | α |
| α + α' | 997 | 432 | α + α' |
| α + α' | 909 | 336 | α + α' |
| α + α' | 850 | 230 | α + α' |
| α + α' | 798 | 456 | α + α' |
| α + α' | 754 | 336 | α + α' |
| α + α' | 706 | 336 | α + α' |
| α + α' | 595 | 480 | α + α' |
| α + α' | 430 | 168 | α + α' |
| α + α' + γ | 500 | 168 | α + α' + γ |
| α + α' + γ | 477 | 168 | α + α' + γ |
| α + α' + γ | -200 | 166 | α + α' + γ |
| α + γ | 477 | 216 | α + γ |
| α + γ | -200 | 168 | α + γ |

^a A, amorphous Nb₂O₅. ^b γ' refers to poorly crystallized γ. ^c α', 2-dimensional α.

The second heat effect is exothermal and coincides with the first appearance of crystallinity. It should be noted that the conversion temperature of amorphous to crystalline Nb₂O₅ obtained with D.T.A. is a function of heating rate. Thus, at 5°/minute the transformation occurred at 580°. At 3°/minute the transformation temperature was 520°. The exotherm is probably the same one observed by Lapitski⁹ at 609°. It is evident that D.T.A. serves only to indicate the presence of a latent heat associated with the amorphous-crystalline transition, and not the true temperature of the phase change. In addition to being rate dependent the inversion temperature was found to be impurity sensitive. For example, if the amorphous Nb₂O₅ prepared by precipitation from carbonate solution is not thoroughly washed, NH₄Cl remains as a contaminant. Approximately 0.5 wt. % NH₄Cl lowered the transition temperature amorphous to crystalline about 200°. This behavior, which is not uncommon, necessitated the excessive washing and digestion procedure used in the preparation of the amorphous oxide.

The "equilibrium" transformation temperature was determined using static methods. Table I, part B, describes the results. The samples of amorphous oxide were heat-treated at the different temperatures for varying lengths of time and then air-quenched. X-Ray diffractometer and Debye Scherrer techniques were then used to determine the phase present. It is seen that 64 hours at 440° showed conversion amorphous-crystalline, 96 hours at 430° showed no conversion. Within the time limits specified the transformation temperature could not be lowered and the "equilibrium" temperature was chosen at 435 ± 5°. It would appear, on the basis of the thermal and X-ray evidence, that the precipitated Nb₂O₅ has no rudimentary crystallinity. If some degree of periodicity were present, heating would serve only to increase crystallite size, and any heat effect would ex-

tend over a large temperature interval making the exotherm undetectable.

What is most interesting about Fig. 2 is that no further heat effects are observed above the exotherm. However, successive heating experiments with fresh samples up to given temperatures, at rates of 1–2°/minute, followed by X-ray examination of the quenched samples, indicated the appearance of new phases. The absence of latent heat concurrent with the appearance of new phases probably indicates that the transformations are second order. It was only possible to isolate the "pure" β -form characterized by Brauer⁴ during these relatively non-equilibrium heating experiments. This behavior will be discussed more fully below.

B. Question of the Existence of δ - and γ -Polymorphs.—Above 440° the δ -modification reported by Frevel and Rinn¹⁰ was found by X-ray analysis. The apparent temperature of transition of the δ form¹⁵ to Brauer's γ -form was lowered by successively longer heat treatments at lower temperatures. These results are listed in Table I, part C. It is seen that progressively longer treatment at each of the transformation temperatures finally results in simultaneous appearance of γ - and δ -phases. On the basis of these results, it is believed that the δ -modification is a less crystalline state of the γ -phase. Examination of X-ray diffractometer traces shows that all of the maxima of the δ -form are characteristic of a material with poorly defined crystallinity. All of the δ -reflections occur as the major lines in the γ -form with increased sharpness, and the additional diffraction lines of the γ -form are all of low intensity. Low intensity maxima would not be observable in the diffuse pattern given by a poorly crystallized

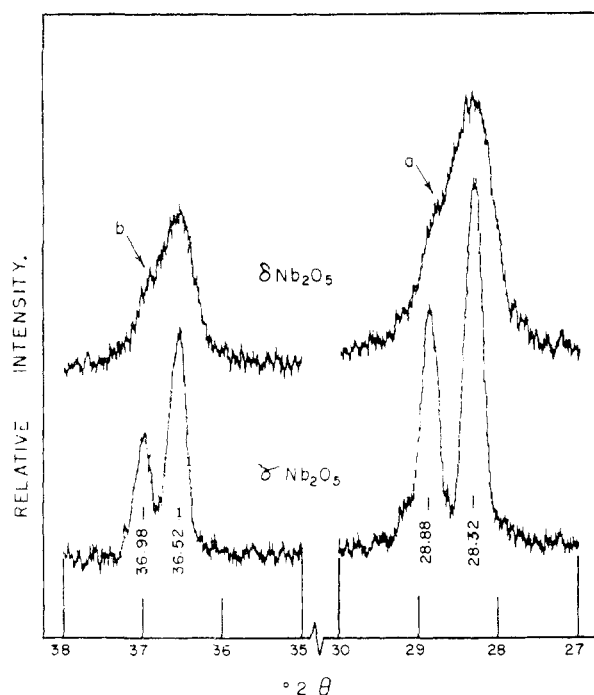

Fig. 3—Partial X-ray diffraction pattern of γ - and δ - Nb_2O_5 .

(15) In Table I the δ -phase is referred to as γ' .

material. For example, as shown in Fig. 3, the broad maxima at 2θ equals 28.34 and 36.53° become resolved into sharp peaks at 28.32, 28.88, 36.52 and 36.98°, respectively. In fact upon careful inspection of the diffractometer traces of the δ -form, it is possible to see evidence of overlap of two diffraction maxima, Fig. 3, points a and b. It is evident, therefore, that the δ - and γ -modifications represent different degrees of crystallinity of the same polymorph.

C. Question of the Existence of β - and α -Polymorphs.—Table I, part D, indicates that the γ -polymorph undergoes a transformation at $830 \pm 5^\circ$. This temperature is in agreement with the upper limits reported by Schäfer, *et al.*, for the appearance of Brauer's β -phase. In the transition of γ to the next modification, one observes the phenomenon of a highly crystalline substance transforming into a material of low crystallinity. As pointed out, the transformation occurs in the absence of an observable latent heat. What is of greatest import is that under equilibrium conditions the γ -polymorph always transformed into a mixture of Brauer's β - and α -forms and, although these modifications appeared simultaneously, further treatment at approximately 1000° for 18 days did not result in complete conversion to the α -form. At 1095°, however, complete conversion of the β - or α' -phase to α was observable.

The question arises as to whether this is the same type of behavior observed for the development of crystallinity in the lower temperature polymorph or whether two crystalline forms exist. From the point of view of X-rays the apparent equilibrium transformation involves the simultaneous formation of two crystalline entities. As previously pointed out pure β - Nb_2O_5 was obtained only under non-equilibrium conditions. The characteristic pattern of the β -form shows broad as well as sharp maxima, and the sharp peaks are identical with peaks occurring in the α -form. The broad maxima can be traced into the formation of sharp doublets in the α -form, and it is difficult to attribute the doublet formation to the same phenomena observed in the lower temperature case because of the large displacement of the center of gravity of the broad maxima in the formation of doublets. One might postulate the occurrence of a two-dimensional periodicity in the apparent drastic structural changes in the transformation γ to α' and α . In such a situation the α' -polymorph might be thought of as a transitional phase. In view of the fact that all of the sharp lines that occur in the α' -form are also present in the α -form, it is conceivable that the sharp lines represent the two-dimensional periodicity of the α -form in the transitional phase. The broad maxima would then be attributable to a disordered structure in the third dimension. Such a hypothesis appears to reconcile the apparent paradox presented between heat treatment data which indicate identity of forms, and X-ray data which indicate two distinct forms.

D. Reversibility of Phases.—It can be seen from Table I, part E, that prolonged heat treatment of the various forms and mixtures of them at

TABLE II
 POWDER DIFFRACTION DATA FOR α -Nb₂O₅

d = interplanar spacing. I/I_1 = relative peak intensity obtained by normalizing with respect to the strongest line. Peak height measured in counts above background. hkl = plane indices. The monoclinic unit cell contains 14 molecules, $a = 21.34$ Å., $b = 3.816$ Å., $c = 19.47$ Å., $\beta = 120^\circ 20'$.

| d Å. meas. | I/I_1 | d Å. calcd. | hkl | d Å. meas. | I/I_1 | d Å. calcd. | hkl | d Å. meas. | I/I_1 | d Å. calcd. | hkl |
|--------------|---------|---------------|--------------|--------------|---------|---------------|--------------|--------------|---------|---------------|------------------|
| 16.9 | 10 | 16.8 | 001 | 3.28 | <10 | 3.28 | 21 $\bar{3}$ | 2.319 | 10 | 2.318 | 20 $\bar{8}$ |
| 10.6 | 20 | 10.7 | 20 $\bar{1}$ | | | 3.27 | 11 $\bar{3}$ | 2.181 | <10 | 2.184 | 81 $\bar{4}$ |
| 9.7 | 10 | 9.7 | 10 $\bar{2}$ | 3.17 | <10 | 3.16 | 20 $\bar{6}$ | | | 2.177 | 81 $\bar{3}$ |
| 9.2 | <10 | 9.2 | 200 | 3.09 | <10 | 3.10 | 41 $\bar{2}$ | 2.112 | <10 | 2.116 | 513 |
| 8.4 | <10 | 8.4 | 002 | 3.01 | <10 | 3.00 | 10 $\bar{6}$ | | | 2.109 | 414 |
| 6.32 | 10 | 6.32 | 10 $\bar{3}$ | 2.84 | 10 | 2.84 | 51 $\bar{2}$ | 2.079 | 10 | 2.081 | 207 |
| 5.60 | <10 | 5.60 | 003 | 2.83 | 10 | 2.83 | 70 $\bar{1}$ | 2.041 | 20 | 2.042 | 10.0. $\bar{7}$ |
| 5.29 | <10 | 5.33 | 40 $\bar{2}$ | 2.78 | 20 | 2.78 | 51 $\bar{1}$ | | | 2.039 | 80 $\bar{9}$ |
| 5.13 | 20 | 5.15 | 40 $\bar{1}$ | 2.71 | 20 | 2.71 | 21 $\bar{5}$ | 2.037 | 10 | 2.036 | 604 |
| 4.74 | <10 | 4.73 | 103 | 2.677 | <10 | 2.681 | 41 $\bar{5}$ | 1.934 | <10 | 1.932 | 117 |
| 4.63 | 20 | 4.64 | 10 $\bar{4}$ | | | 2.677 | 20 $\bar{7}$ | 1.915 | 20 | 1.914 | 712 |
| 3.83 | <10 | 3.82 | 010 | 2.635 | <10 | 2.637 | 11 $\bar{5}$ | 1.876 | <10 | 1.878 | 22 $\bar{1}$ |
| 3.75 | 70 | 3.77 | 40 $\bar{5}$ | 2.549 | 10 | 2.552 | 10 $\bar{7}$ | 1.857 | <10 | 1.858 | 10.1. $\bar{4}$ |
| 3.74 | 50 | 3.74 | 110 | 2.537 | <10 | 1.544 | 503 | | | 1.855 | 208 |
| 3.65 | 100 | 3.65 | 10 $\bar{5}$ | | | 2.531 | 404 | 1.822 | 10 | 1.822 | 320 |
| 3.56 | <10 | 3.57 | 111 | | | 2.531 | 412 | 1.793 | 10 | 1.791 | 902 |
| | | 3.55 | 11 $\bar{2}$ | 2.529 | <10 | 2.528 | 313 | 1.762 | <10 | 1.761 | 10.0. $\bar{10}$ |
| 3.49 | 50 | 3.50 | 21 $\bar{2}$ | 2.496 | 10 | 2.504 | 806 | 1.744 | 10 | 1.743 | 11 $\bar{9}$ |
| 3.41 | <10 | 3.44 | 60 $\bar{4}$ | 2.483 | <10 | 2.482 | 511 | 1.694 | 10 | 1.694 | 520 |
| | | 3.38 | 402 | 2.457 | <10 | 2.459 | 61 $\bar{5}$ | 1.685 | 10 | 1.687 | 3.1. $\bar{10}$ |
| 3.36 | 10 | 3.36 | 005 | 2.451 | <10 | 2.453 | 80 $\bar{1}$ | 1.590 | <10 | 1.591 | 522 |
| 3.32 | <10 | 3.32 | 211 | 2.340 | <10 | 2.340 | 90 $\bar{3}$ | 1.584 | 10 | 1.582 | 10.1.1 |
| | | | | | | | | 1.557 | 10 | 1.556 | 904 |

varying temperature increments beneath their transformation temperatures did not result in reversal of transformations, which is in agreement with the results obtained by Brauer.

In view of the inability to invert higher to lower temperature polymorphs, the term "equilibrium" as employed in this paper refers only to the results obtained within the limits of the experiments tabulated in Table I.

The densities of the polymorphs of Nb₂O₅, determined using the method previously described,¹ are as follows: amorphous 4.36 g./cm.³ at 25°, γ , 5.17 g./cm.³ at 25°, α 4.55 g./cm.³ at 25°.

The freezing point obtained in this study using D.T.A. cooling curve techniques was $1491 \pm 2^\circ$ which is slightly higher than the value originally reported.³

Magneli and Lagergren¹⁶ indexed α -Nb₂O₅ on the basis of a monoclinic unit cell using data obtained with a Guinier focusing camera. They reported $a = 21.50$ Å., $b = 3.825$ Å., $c = 20.60$ Å. and $\beta = 121^\circ 45'$. Using these parameters the cell was found to contain 14 molecules with an X-ray density of 4.29 g./cm.³. Apparently an error is present in the A.S.T.M. card since the indices recorded are not consistent with the above lattice constants. Using the data obtained from single crystal precession photographs the powder lines listed in Table II were reindexed. The monoclinic

(16) A. Magneli and S. Lagergren A.S.T.M. #5-0379.

cell was found to have $a = 21.34$ Å., $b = 3.816$ Å., $c = 19.47$ Å. and $\beta = 120^\circ 20'$ with 14 molecules/unit cell. The X-ray density is 4.52 g./cm.³.

Frevel and Rinn indexed the γ -phase on the basis of a monoclinic unit cell with $a = 7.31$ Å., $b = 15.72$ Å., $c = 10.75$ Å., $\beta = 120^\circ 41'$ with 12 molecules per unit cell. The X-ray density calculated from their data is 4.99 g./cm.³, which is in poor agreement with the pycnometric density reported above. Attempts to reindex the γ -form directly from powder data were unsuccessful. Although heat treatment of the γ -phase for a month just below the γ - to α -transformation temperature appreciably improved the sharpness of diffraction maxima, the resolution was still insufficient to enable unequivocal indexing of this form. Consequently until a method is devised for growth of single crystals of this phase, the choice of unit cell is questionable.

The difference between the high temperature Nb₂O₅ and Ta₂O₅ phases indicated that the mixed oxide system would probably not form a continuous series of solid solutions. Preliminary investigation of this system, contrary to Schäfer's observations, showed a miscibility gap at approximately 25 mole % Ta₂O₅.

A complete investigation of the heterogeneous equilibria in the system Ta₂O₅-Nb₂O₅ is presently in progress and will be reported at a later date.

NEW YORK 25, N. Y.